

PCB Laser Drilling Systems



ProVia Series

- Integrated Laser Drilling Tool for High Volume Production
- Single- and Dual-Head Configurations
- APS for Superior Process Quality
- CO₂, UV, and Hybrid (UV+CO₂) Processing
- Horizontal or Semi-Vertical Load/Unload
- Slip Sheet and Panel Flipper Options
- WindowsXP® Operator Interface

Designed for Next-Generation High Volume Via Drilling Requirements:

- Optional dual-head configuration for optimum throughput
- CO₂ via sizes down to 80µm diameter
- UV via sizes down to 40µm diameter
- High accuracy <15µm for both UV and CO₂
- High speed load / unload / alignment
- Built-in cutting, routing, skiving and marking functions

Advanced ProSys Control Software

- Perform drill file conversion and job generation
- Provides a map of the job features and status on progress of the job
- Custom tool creation and assignment

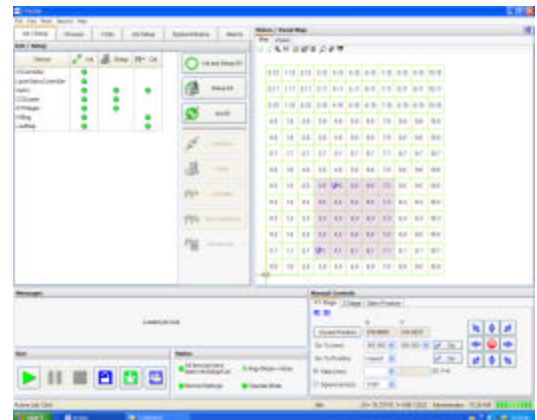

PCB Laser Drilling Systems

The ProVia drillers provide the ultimate processing workstation for rigid boards, with high performance galvos for rapid point-to-point drilling and precise control for fine features. The CO₂ laser is appropriate for high speed machining (drilling, cutting and skiving) of dielectrics, while the UV laser is able to machine copper and provide higher process quality in many dielectrics. An optional second galvo head for CO₂-only or UV-only systems can increase drilling speeds up to 2X over the standard single-head configuration. Whether your application is with glass- and aramid-reinforced epoxies or non-reinforced materials (e.g. resin-coated foil), there is a ProVia model to meet your requirements.

ProVia Specifications*

System Hardware

- High peak power RF-excited CO₂ laser and diode-pumped solid state UV laser (3W to 20W models)
- Configured with high performance galvanometer scanners for high speed via drilling, skiving, and cutting
- Three drilling modes: hybrid, conformal mask CO₂, direct CO₂
- Galvanometer scanning field: 50 x50 mm (approx. 2" x 2")
- Maximum panel size: 533mm x 635mm (21"x25")
- Vacuum platen for panel hold-down
- Integrated power meter for accurate process control
- Precision linear motor XY stages with linear encoder feedback
- High performance motion and laser controller
- CDRH Class 1 enclosure
- Large process viewing window
- Automated vision system for precision alignment, and scaling, offset, trapezoidal and rotation compensation
- Beam placement accuracy: 15µm (3 sigma) over panel process area
- Ultrastable steel weldment frame with resonance dampening
- Compliant with CE and North American regulations
- Optional second galvo head (for CO₂-only and UV-only systems)
- Optional automatic panel loader / unloader, available in semi-vertical or horizontal configuration

Utilities

- Electrical: 208VAC, 3φ, 35A, 60Hz, or 400VAC, 3φ, 20A, 50Hz
- Exhaust: ablation debris removal through 3" diameter duct
- Dimensions (HxWxD): 2356 x 1626 x 2192 mm (93"x64"x86")
- Weight: 2813 kg (6233 lbs) net; 3437 kg (7563 lbs) shipping
- Water: 8 l/min, or optional closed cycle water chiller

System Control

- WindowsXP® based user interface
- User friendly operator screens
- Compatible with industry standard file formats
- Rapid drill file conversion and path optimization utility
- Full system diagnostics
- Password protection for access to configuration, set-up, and operating screens
- System monitoring for process integrity
- Saving of multiple job parameter files
- Emergency stop and safety interlock circuits
- Optional network interface

Process Parameters

- Active Pulse Shaping™ for the CO₂ laser to optimize process quality
- Point-to-point moves, continuous line and area scanning, and circuit excising
- Programmable laser pulse rate, pulse overlap, and scanning area
- Tool creation function
- Automatically process stepped vias
- Via sizes down to 40µm using UV and 80µm using CO₂
- Via roundness error: 10% maximum
- Drilling rates up to 500 blind vias/sec within galvo field
- Cutting rates up to 1000 mm/sec (CO₂), 100 mm/sec (UV) in non-reinforced material
- Consult PPI for processing rates in your material.

*specifications are subject to revision

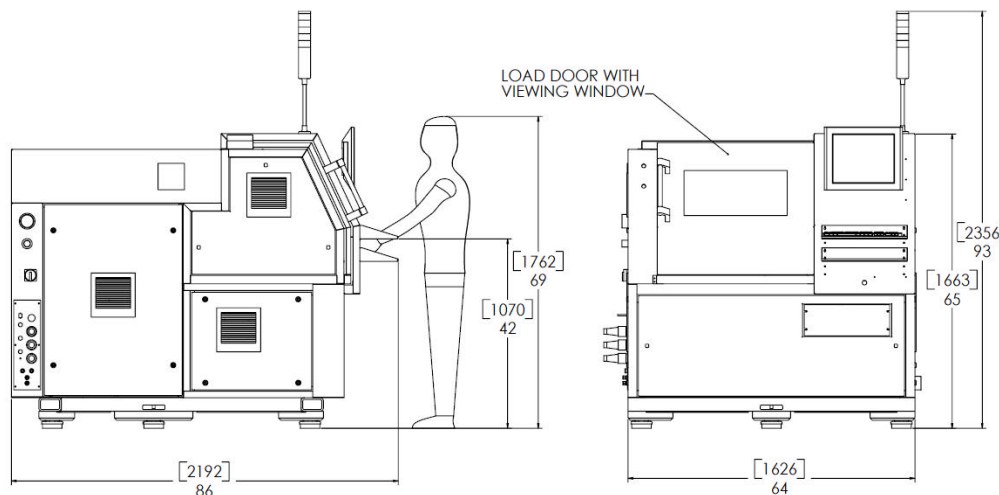

Shown without autoload/unload option.

Contact the team at Process Photonics for help with your process requirements.

PPI Systems Inc.
1051 Baxter Road
Ottawa, Ontario K2C 3P2
Canada
Tel: (613) 236-8359
Fax: (613) 248-4820
www.processphotonics.com
info@processphotonics.com

Process Photonics